



AVANT  
TECHNOLOGY  
CUTTING-  
EDGE DESIGN  
TOUCH  
SCREEN



# AVANT

The most technologically advanced range in the GM Global Solutions catalogue, featuring cutting-edge design, Raspberry Pi processor and product selection touch screen. Thanks to its advanced technology combined with enhanced user experience, the AVANT is the most effective solution on the market.

## Touch screen

- No labels.
- No pushbuttons.
- Brands and prices are always up-to-date, thanks to the remote control system.
- Clearly displayed brands and prices.
- Smart, dynamic screen guide for the notes and coins accepted.
- The product icon increases in size when pressed.
- 5 different screen configuration options in a single machine: 15, 18, 28, 40 and 60 selections.

## Advanced technology

### RASPBERRY PI

- Universal technology.
- Minimum maintenance.
- No hard drive, no moving parts, operating stability.



BILL READER



COIN CHANGE GIVER



17" TOUCH SCREEN



SUPER KING CHANNELS



TELEMETRY CONNECTION WITH GMBOS

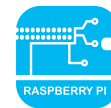

RASPBERRY PI PROCESSOR



LED LIGHTING



TOUCH CONTROL



CREDIT CARD



HOPPER



## AVANT

Withstands up to 50 million touches on the same spot with no failures or wear due to use.



## Telemetry + touch screen

The real-time management of all machines online, simply through an internet connection, smartphone, tablet or PC.

- Price changes.
- Brand updates.
- Screen configuration change.
- Plus all the advantages of the GMBOS telemetry system:
  - Sales reports.
  - Technical and monetary status reports.
- Stock control, replenishments and cash-ups.

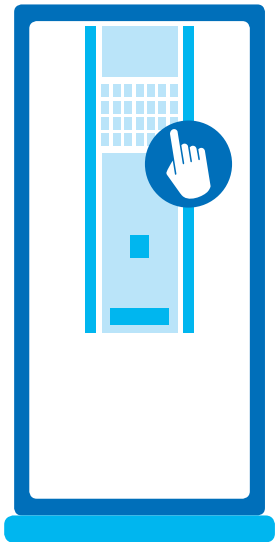

## NEW DESIGN

The new elegant design, conveys an image of quality and cutting-edge technology



TOUCH CONTROL

Increased brightness.

LED lighting. Up to 7 colours

80% saving in energy consumption.

Elevated product delivery. Greater convenience for the replenisher and user alike.



## TECHNICAL SPECIFICATIONS

| Model       | Capacity         | Channels | Decals | Screen options                | Dimensions mm<br>(height x width x depth) | Weight | Payment systems                    | Hopper           | Super king<br>Channels | Voltage      | Connection<br>type |
|-------------|------------------|----------|--------|-------------------------------|---|--------|------------------------------------|------------------|------------------------|--------------|--------------------|
| AVANT M 23  | 525<br>packets   | 23       | 28     | 15/18/28/40/60<br>pushbuttons | 1700 x 650 x 380                          | 128 kg | Coin change giver<br>+ bill reader | Pre-installation | 5                      | 230V - 50 Hz | Single-phase       |
| AVANT L 30  | 745<br>packets   | 30       | 28     | 15/18/28/40/60<br>pushbuttons | 1700 x 650 x 510                          | 143 kg | Coin change giver<br>+ bill reader | Hopper 5 cc      | 5                      | 230V - 50 Hz | Single-phase       |
| AVANT XL 30 | 1.095<br>packets | 30       | 40     | 15/18/28/40/60<br>pushbuttons | 1700 x 650 x 670                          | 155 kg | Coin change giver<br>+ bill reader | Hopper 5 cc      | -                      | 230V - 50 Hz | Single-phase       |
| AVANT XL 39 | 1.040<br>packets | 39       | 40     | 15/18/28/40/60<br>pushbuttons | 1700 x 650 x 670                          | 163 kg | Coin change giver<br>+ bill reader | Hopper 5 cc      | 7                      | 230V - 50 Hz | Single-phase       |

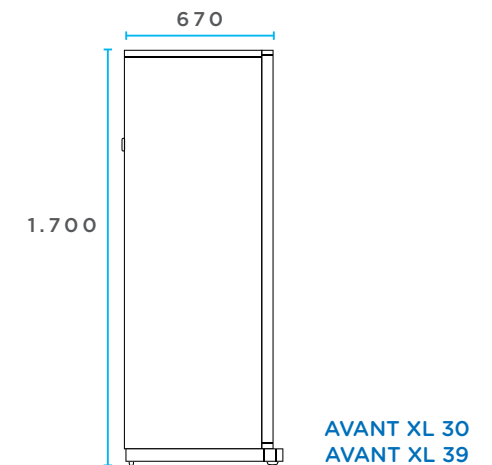
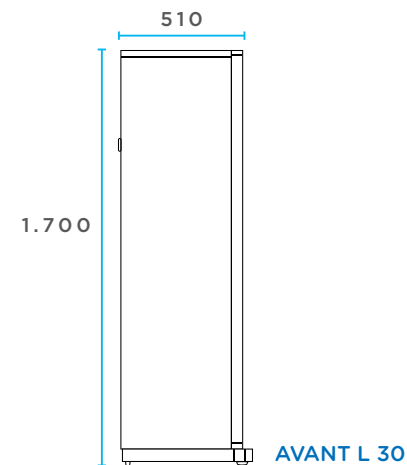
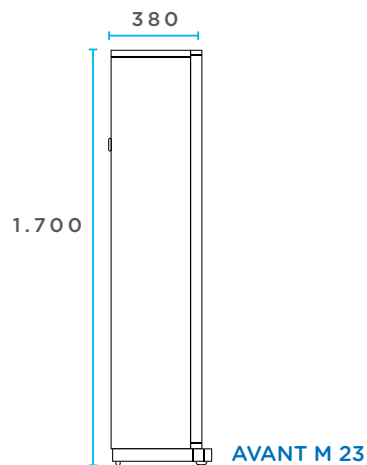
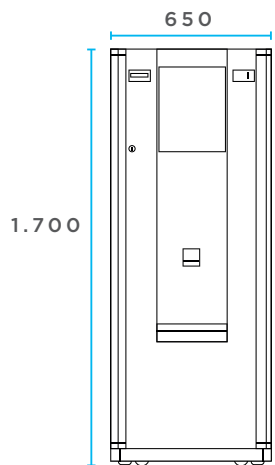

### Standard equipment

- Raspberry Pi Processor
- 17" SAW touchscreen
- Different screen configurations
- Bill reader (5€ + 10€)
- Coin change giver
- Pre-installation of hopper
- 5cc Hopper (Avant L and XL)
- Door open sensor
- Cash box with lock
- Super king channels
- Security keys
- GMBOS telemetry system
- Touch remote for age verification
- Casters and levelling feet

### Optional equipment

- Hopper (one or two)
- Credit card payment module
- Master key
- RS232 Connector
- Tobacco rolling kit

### GM Global Solutions

Polígono Vizcaya Calle A, 6  
31119 Torres de Elorz - Navarra - Spain

+34 948 317 311

[comercial@gmglobalsolutions.com](mailto:comercial@gmglobalsolutions.com)  
[www.gmglobalsolutions.com](http://www.gmglobalsolutions.com)

GMGS0015